

XPM10 Miniature pressure sensor



- Absolute, sealed and gauge ranges 1 to 350 bars [15 psi to 5 000 psi]
- Stainless steel or titanium
- High level output in option
- For static and dynamic applications
- Linearity up to $\pm 0.25\%$ F.S.

DESCRIPTION

The XPM10 is a miniature transducer designed to measure static and dynamic pressure under a wide variety of conditions, including hostile environments. It is made of stainless steel or titanium and is available in standard ranges from 0-1 to 350 bars [15 up to 5000 psi].

The XPM10 incorporates Measurement Specialties' cutting edge SanShift™ technology, which virtually eliminates zero shifts caused by installation torque.

The XPM10's sensing element is a fully temperature compensated Wheatstone bridge made with high stability micro-machined silicon strain gauges which optimize performance, especially at low ranges and frequencies. An on-board A1 or A2 amplifier for high level output is optionally available for all ranges, and an electrical connector interface is available for the standard low level output version.

With many years of experience as a designer and manufacturer of sensors, Measurement Specialties, Inc. has the expertise to customize and/or design sensors for specific uses and testing environments. To meet your needs we also offer complete turnkey systems. Our conditioning electronics can power the sensor, amplify the electronic signal, and display the data digitally. A turnkey measurement system arrives with matched components, formatted, calibrated and ready for your immediate use.

FEATURES

- Flush Diaphragm
- Low Installation Torque Sensitivity
- M10x1 thread
- High Level Tension Output Available
- For Static and Dynamic Applications

APPLICATIONS

- Hydraulic regulation process
- Explosion test benches
- Onboard equipment monitoring
- Breaking system pressure
- Laboratory and research

STANDARD RANGES

Range in bar	0-1	0-2	0-5	0-10	0-20	0-35	0-50	0-100	0-200	0-350
Range in psi	0-15	0-30	0-75	0-150	0-300	0-500	0-750	0-1500	0-3000	0-5000

XPM10 Miniature pressure sensor

CHARACTERISTICS

Ambient Temperature: 20±1°C (unless otherwise specified)

Parameters	
Operating Temperature Range (OTR)	-40 to 120 ° C [-40 to 248 ° F]
Compensated Temperature Range (CTR)	0 to 60 ° C [32 to 140 ° F]
Zero Shift in CTR	<2% F.S. /60 ° C [/108 ° F] - <7% for 2bar [30psi] model
Sensitivity Shift in CTR	<2% of reading /60 ° C [/108 ° F]
Range (F.S.)	See standard ranges table
Tightening Torque	
Nominal (Zero and sensitivity shift <1%)	5 N.m [44 Lbf.in] for ≤5 bar [75 psi] models, 10 N.m [88 Lbf.in] for other ranges
Maximal	10 N.m [88 Lbf.in] for ≤5 bar [75 psi] models, 15 N.m [132 Lbf.in] for other ranges
Over-Range	
Without Damage	2x F.S.
Without Destruction	5x F.S.
Accuracy	
Linearity	±0.25% F.S. for ≥ 1bar [15psi] model ±0.35% F.S. for 1bar [15psi] model
Hysteresis	±0.25% F.S.
Repeatability	±0.2%F.S.

Electrical Characteristics

Model	XPM10	XPM10-A1	XPM10-A2
Power Supply	10 Vdc	10 to 30 Vdc	±15 Vcc (±12 to ±18 Vdc)
F.S. Output (2bar model)	50 mV	4 V ±5% F.S.	5 V ±5% F.S.
F.S. Output (>2bar model)	100 mV	4 V ±5% F.S.	5 V ±5% F.S.
Zero Offset	<±10 mV	0.5 V ±5% F.S.	0 V ±5% F.S.
Input Impedance/Consumption	500 to 1500 Ω	<25 mA	<25 mA
Output Impedance	500 to 800 Ω	<10 Ω	<10 Ω
Insulation under 50Vdc	≥100 MΩ	≥100 MΩ	≥100 MΩ

Notes

1. Electrical Termination: Shielded Ø3 mm Silastene cable with 4 Teflon wires (AWG30), standard length 2.0 m [6.6 ft] with strain relief spring
2. Material: Body and flush diaphragm in stainless steel or titanium; laser welded
3. Protection Index: IP50
4. Resonance Frequency: 20-200kHz depending on range
5. Self-centered, sealing ring

XPM10 Miniature pressure sensor

DIMENSION & WIRING SCHEMATIC (IN METER AND IMPERIAL)

XPM10

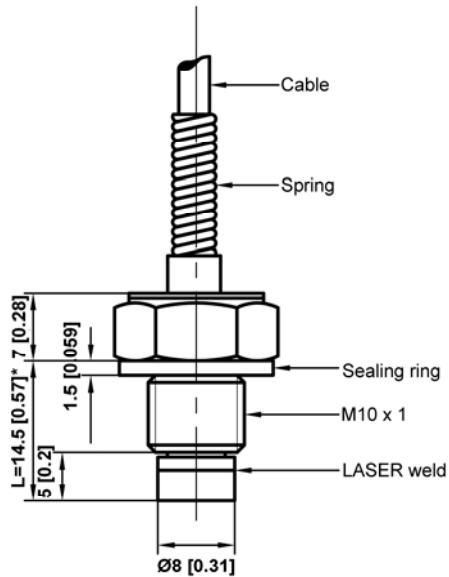

XPM10-A1/A2

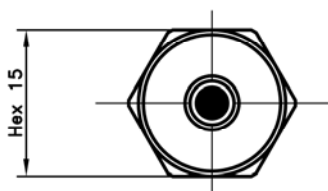
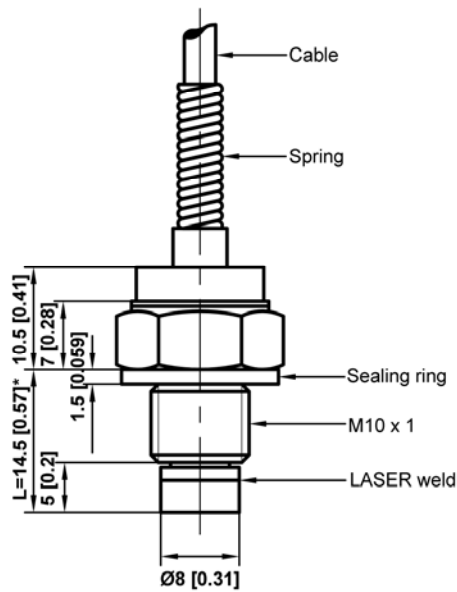

Wiring Schematic

XPM10

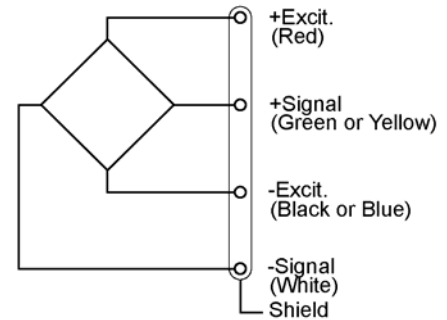

XPM10-A1

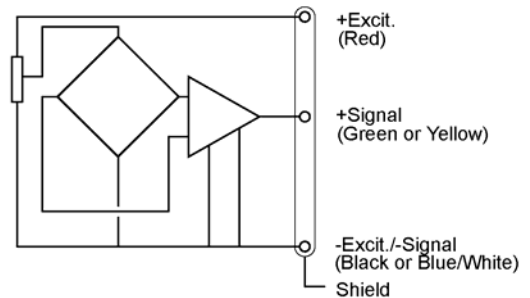

XPM10-A2

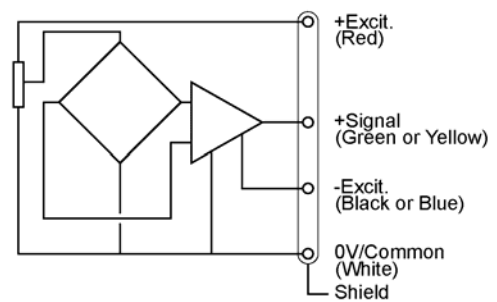

XPM10 Miniature pressure sensor

OPTIONS

A : Absolute
G : Gauge
S : Sealed Gauge
A1 : Unipolar Tension
A2 : Bipolar Tension
HA : High Accuracy (CN L&H) $\leq \pm 0.25\%$ F.S. ($\leq \pm 0.35\%$ F.S. for 1 bar [15psi] model)
SI : Sensitivity shift in CTR $\leq 1\%$ of reading / 60°C [108°F] (except 1 and 2 bar [15, 30 psi] models)
ZI : Zero shift in CTR $\leq 1.5\%$ F.S. / 60°C [108°F] (except 1 and 5 bar [15, 30 psi] models)
ET1 : CTR -20 to 100°C [-4 to 212°F]
ET3 : CTR -40 to 150°C [-40 to 302°F] OTR=CTR (not available with A1 and A2 options)
SC : Connector output, prewired, cable length 2 m [6.6 ft]
TT : Titanium version
P5 : IP65 protection
P7 : IP67 protection
LC"X" : Additional Cable length in meter ("X" = custom value)

ORDERING INFORMATION

XPM10 - A1 - 20BG - /ET1/LC "x"

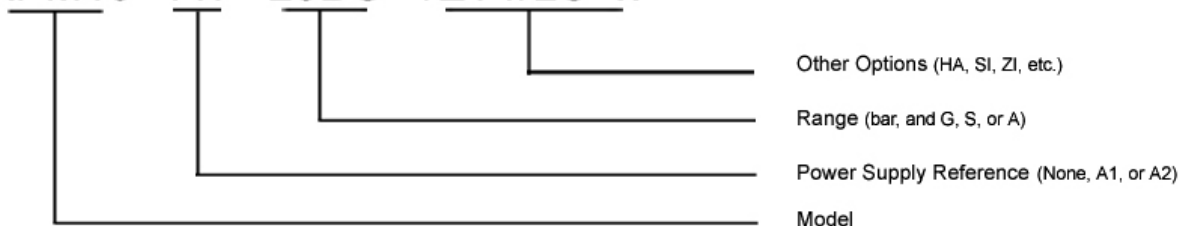

NORTH AMERICA

Measurement Specialties Inc.
1000 Lucas Way
Hampton, VA 23666
USA
Tel: 1-757-766-1500
Fax: 1-757-766-4297
pvg.cs.amer@meas-spec.com

EUROPE

Measurement Specialties
(Europe), Ltd.
26 Rue des Dames
78340 Les Clayes-sous-Bois,
France
Tel: +33 (0) 130 79 33 00
Fax: +33 (0) 134 81 03 59
pfg.cs.emea@meas-spec.com

ASIA

Measurement Specialties
(China), Ltd.
No. 26 Langshan Road
Shenzhen High-Tech Park (North)
Nanshan District, Shenzhen
518107
China
Tel: +86 755 3330 5088
Fax: +86 755 3330 5099
pfg.cs.asia@meas-spec.com

The information in this sheet has been carefully reviewed and is believed to be accurate; however, no responsibility is assumed for inaccuracies. Furthermore, this information does not convey to the purchaser of such devices any license under the patent rights to the manufacturer. Measurement Specialties, Inc. reserves the right to make changes without further notice to any product herein. Measurement Specialties, Inc. makes no warranty, representation or guarantee regarding the suitability of its product for any particular purpose, nor does Measurement Specialties, Inc. assume any liability arising out of the application or use of any product or circuit and specifically disclaims any and all liability, including without limitation consequential or incidental damages. Typical parameters can and do vary in different applications. All operating parameters must be validated for each customer application by customer's technical experts. Measurement Specialties, Inc. does not convey any license under its patent rights nor the rights of others.