

XPCM10 High temperature miniature pressure sensor



- Absolute, sealed and gauge ranges
10 to 350 bars [150 to 5 000 psi]
- High Temperature up to 220 °C [428 ° F]
- Stainless steel housing
- High level output in option
- For static and dynamic applications
- High stability

DESCRIPTION

The XPCM10 is a miniature transducer designed to measure static and dynamic pressures in high temperatures up to 220 °C [428 ° F] (unamplified models). It is made of stainless steel and available in standard ranges from 0-10 to 0-350 bar [150 up to 5000 psi].

The XPCM10 incorporates Measurement Specialties' cutting edge SanShift™ technology, which virtually eliminates zero shifts caused by installation torque.

Fitted with metallic strain gauges in a Wheatstone bridge circuit, the XPCM10 provides excellent temperature stability. It is available in standard ranges from 150 psi up to 5000 psi. An on-board A1 or A2 amplifier for high level output is optionally available for all ranges.

With many years of experience as a designer and manufacturer of sensors, Measurement Specialties, Inc. has the expertise to customize and/or design sensors for specific uses and testing environments. To meet your needs we also offer complete turnkey systems. Our conditioning electronics can power the sensor, amplify the electronic signal, and display the data digitally. A turnkey measurement system arrives with matched components, formatted, calibrated and ready for your immediate use.

FEATURES

- Temperature from -75 to 220 ° C [-103 to 428 ° F]
- Low Installation Torque Sensitivity
- M10x1 thread
- Linearity up to $\pm 0.2\%$ F.S.
- For Static and Dynamic Applications

APPLICATIONS

- Aerospace
- Explosion test benches
- Oven monitoring equipment
- Cooling regulation systems
- Laboratory and research

STANDARD RANGES

Range in bar	0-10	0-20	0-35	0-50	0-100	0-200	0-350
Range in psi	0-150	0-300	0-500	0-750	0-1500	0-3000	0-5000

XPCM10 High temperature miniature pressure sensor

CHARACTERISTICS

Ambient Temperature: 20±1°C (unless otherwise specified)

Parameters		
Operating Temperature Range (OTR)	Without A1/A2 option	-75 to 220 ° C [-103 to 428 ° F]
	With A1/A2 option	-55 to 125 ° C [-67 to 257 ° F]
Compensated Temperature Range (CTR)	Without A1/A2 option	0 to 150 ° C [32 to 302 ° F]
	With A1/A2 option	0 to 100 ° C [32 to 212 ° F]
Zero Shift in CTR		<1% F.S. /50 ° C [/90 ° F]
Sensitivity Shift in CTR		<1% of reading /50 ° C [/90 ° F]
Range (F.S.)		See standard ranges table
Tightening Torque		
Nominal (zero and sensitivity shift <1%)		10 N.m [88 Lbf.in]
Maximal		15 N.m [132 Lbf.in]
Over-Range		
Without Damage		1.5x F.S.
Without Destruction		3x F.S.

Accuracy

Range in bar [in psi]	10 [150]	20 [300]	35 [450]	50 [750]	100 [1 500]	200 [3 000]	350 [4 500]
Linearity (% F.S.)	±0.5	±0.5	±0.3	±0.3	±0.2	±0.2	±0.2
Hysteresis (% F.S.)	±0.3	±0.3	±0.2	±0.2	±0.2	±0.2	±0.2
Repeatability (% F.S.)	±0.1	±0.1	±0.1	±0.1	±0.1	±0.1	±0.1
Option HA (CN L&H in % F.S.)	±0.5	±0.5	±0.3	±0.3	±0.2	±0.2	±0.2

Electrical Characteristics

Model	XPCM10	XPCM10-A1	XPCM10-A2
Power Supply	10 Vdc	10 to 30 Vdc	±15 Vdc (±12 to ±18 Vdc)
F.S. Output	10 mV typical	4 V ±5% F.S.	5 V ±5% F.S.
Zero Offset	<±5% F.S.	0.5 V ±5% F.S.	0 V ±5% F.S.
Input Impedance/Consumption	350 Ω	<25 mA	<25 mA
Output Impedance	350 Ω	<10 Ω	<10 Ω
Insulation under 50Vdc	≥100 MΩ	≥100 MΩ	≥100 MΩ

Notes

1. Electrical Termination: Shielded Ø3 mm Silastene cable with 4 Teflon wires (AWG30), standard length 2.0 m [6.6 ft] with strain relief spring
2. Material: Body and flush diaphragm in stainless steel; laser welded
3. Protection Index: IP50
4. Resonance Frequency: 25-150kHz depending on range
5. Self-centered, sealing ring

XPCM10 High temperature miniature pressure sensor

DIMENSION & WIRING SCHEMATIC (IN METER AND IMPERIAL)

XPCM10

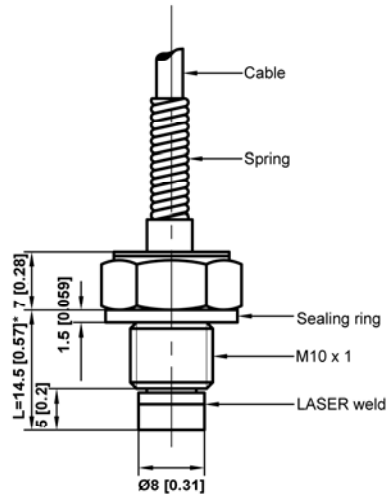

XPCM10-A1/A2

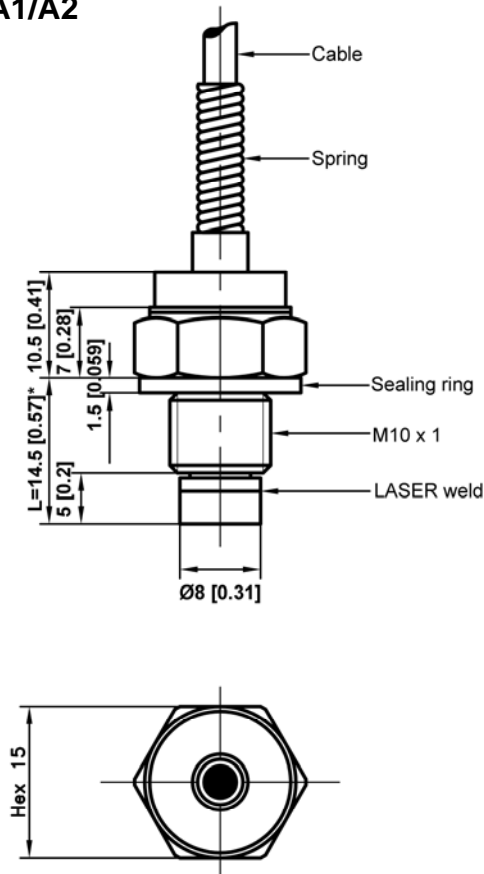

Custom length L = 12 to 50 mm [0.47" to 1.97"] on request.

Wiring Schematic

XPCM10

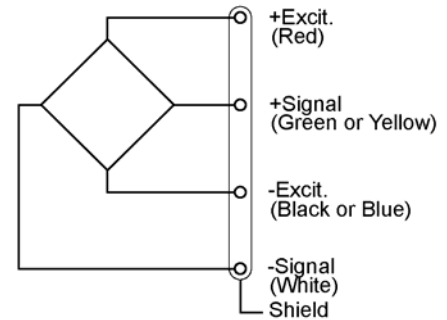

XPCM10-A1

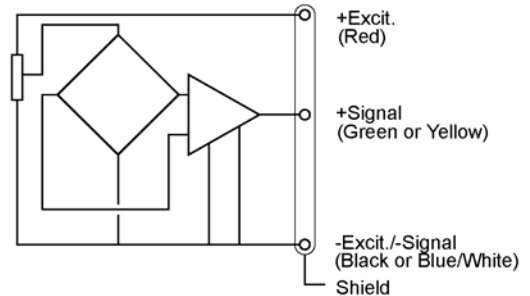

XPCM10-A2

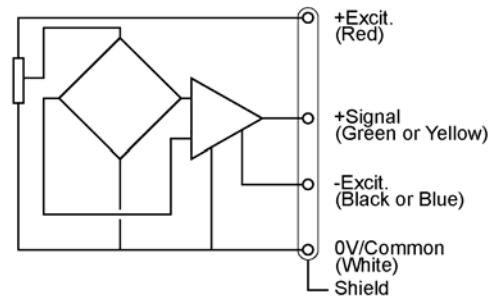

XPCM10 High temperature miniature pressure sensor

OPTIONS

A : Absolute
G : Gauge
S : Sealed Gauge
A1 : Unipolar Tension (check availability with CTR)
A2 : Bipolar Tension (check availability with CTR)
HA : High Accuracy (see table below)
SI : Sensitivity shift in CTR $\leq 1\%$ of reading / 100 ° C [/180 ° F]
ZI : Zero shift in CTR $\leq 1.5\%$ F.S. / 100 ° C [/180 ° F]
ET"X" : Custom CTR between -70 to 200 ° C [-94 to 392 ° F] (check availability with A1 and A2 options)
P5 : IP65 protection
P7 : IP67 protection
LC"X" : Additional Cable length in meter ("X" = custom value)

ORDERING INFORMATION

XPCM10 - A1 - 20BG - /LC"X"

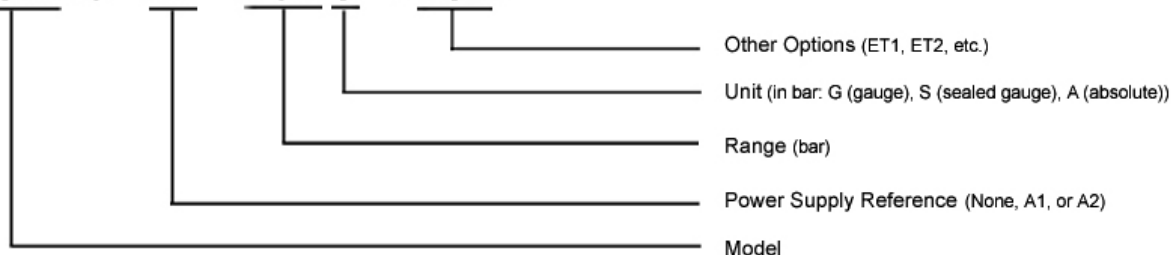

NORTH AMERICA

Measurement Specialties Inc.
1000 Lucas Way
Hampton, VA 23666
USA
Tel: 1-757-766-1500
Fax: 1-757-766-4297
pvg.cs.amer@meas-spec.com

EUROPE

Measurement Specialties
(Europe), Ltd.
26 Rue des Dames
78340 Les Clayes-sous-Bois,
France
Tel: +33 (0) 130 79 33 00
Fax: +33 (0) 134 81 03 59
pfg.cs.emea@meas-spec.com

ASIA

Measurement Specialties
(China), Ltd.
No. 26 Langshan Road
Shenzhen High-Tech Park (North)
Nanshan District, Shenzhen
518107
China
Tel: +86 755 3330 5088
Fax: +86 755 3330 5099
pfg.cs.asia@meas-spec.com

The information in this sheet has been carefully reviewed and is believed to be accurate; however, no responsibility is assumed for inaccuracies. Furthermore, this information does not convey to the purchaser of such devices any license under the patent rights to the manufacturer. Measurement Specialties, Inc. reserves the right to make changes without further notice to any product herein. Measurement Specialties, Inc. makes no warranty, representation or guarantee regarding the suitability of its product for any particular purpose, nor does Measurement Specialties, Inc. assume any liability arising out of the application or use of any product or circuit and specifically disclaims any and all liability, including without limitation consequential or incidental damages. Typical parameters can and do vary in different applications. All operating parameters must be validated for each customer application by customer's technical experts. Measurement Specialties, Inc. does not convey any license under its patent rights nor the rights of others.